

# Crystal Grid Guides

## VITALITY

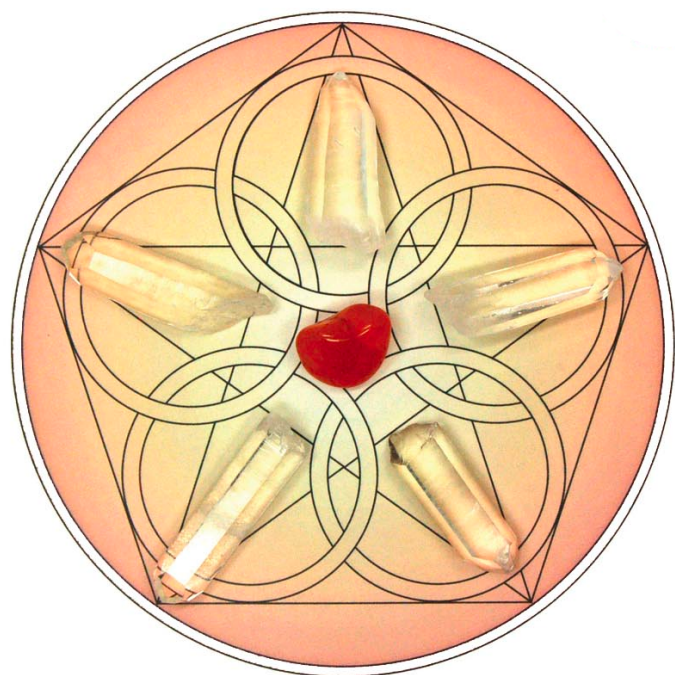
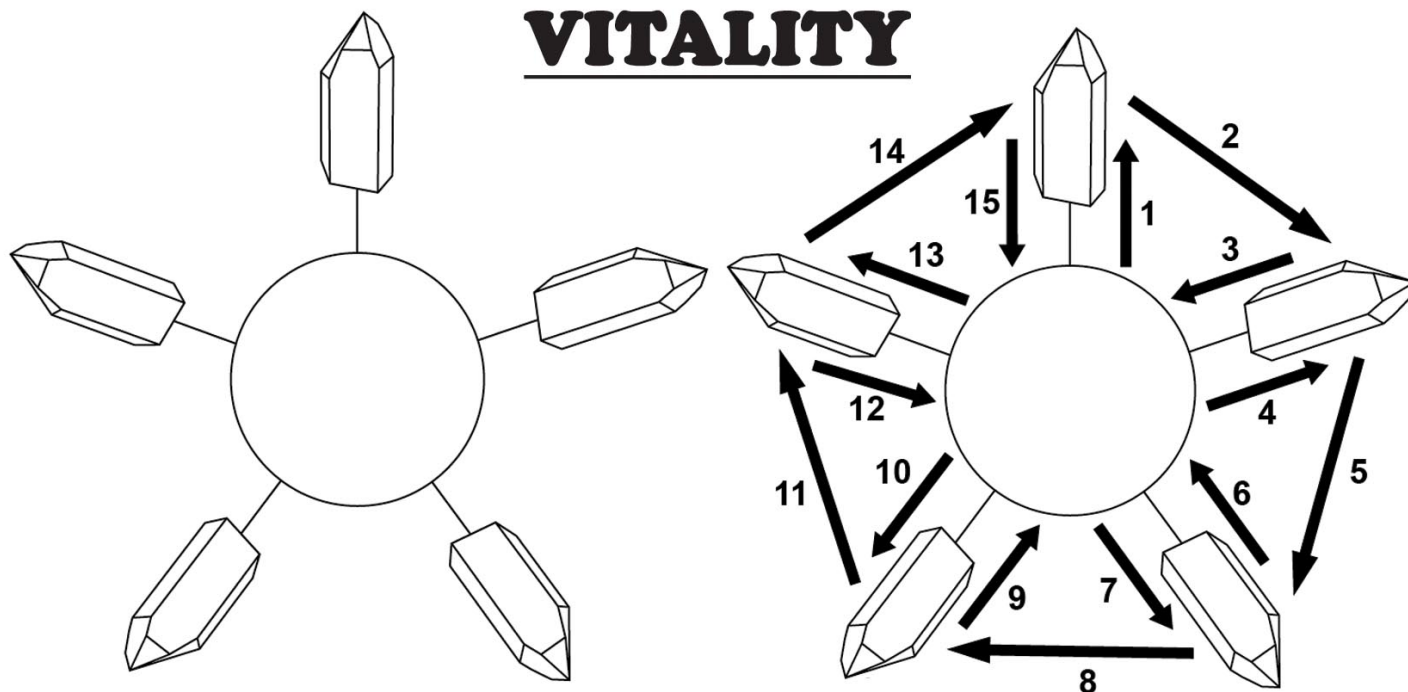

This simple grid includes a central Carnelian crystal surrounded by five Clear Quartz points. Carnelian and Clear Quartz are helpful for boosting physical vitality. The outer crystals point away from the center of the grid. This will radiate energy out, sending the energetic intention from the central stone. Alternately, you may choose to point the outer crystals toward the center in order to draw energy inward and amplify the vibration of the center stone. These are the suggested ways to set up this simple grid, but the layout can always be modified as your intuition guides you.

### Instructions:

Once you have set up the grid in an area where it is unlikely to be disturbed, activate the grid by tracing it using a crystal point, a wand or your pointed finger. Start with the center (#1) crystal and trace outward to the tip of each crystal and then back into the center before moving on to the next crystal. Do this for each point in the grid, ending back in the center of the grid. While activating your grid, concentrate and hold the intention in your mind of protection from negative energies.

